

# Model 221 Pressure Transducers (A300): Accurate, Stable Operation

The Model 221 family of transmitters senses changes in pressure in closed piping systems or changes in water level in open sumps or tanks. Operating within a factory-calibrated range in PSIG or feet of water, the 221 transmitters provide stable conversion of sensed pressures to standard instrumentation signals. Accuracy has been tested at better than 1/2 of 1%. Applications include elevated and ground storage water tanks, reservoirs, distribution systems and bubbler systems.

- Various models offer input power and output signal selections.
  - Six pressure-range options (spannable down to 15% of element range).
  - Isolated from mineral deposits.
  - Options include:
    - Shut-off and bleed valves
    - 3.5" (8.9 cm) gauge
    - Open construction or weatherproof enclosure
- the 221 is capable of measuring system
- Electronic indicators

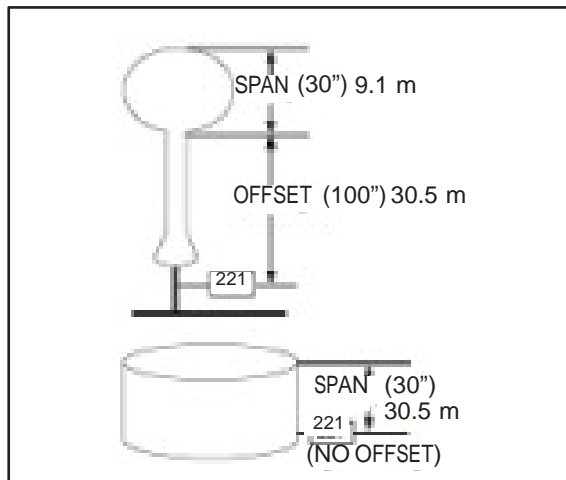

The 221 is capable of measuring system pressure with or without offset.

## 221 Features

- Pressure range, PSI to Bar:
  - 0-5 = 0 - 0.3
  - 0-15 = 0 - 1.0
  - 0-30 = 0 - 2.1
  - 0-75 = 0 - 5.2
  - 0-150 = 0 - 10.13
  - 0-200 = 0 - 13.8
- Choice of three electronics packages: 4-20m ADC 2-wire, 4-wire or 1-5V DC3-wire
- Non-interactive coarse and fine span and offset
- Spannable down to 15% of element range
- Transient and environmentally protected electronics
- Accurate/stable performance
- Feet of water or PSIG calibration

## Water, Wastewater and Process Applications

- Waterworks distribution system pressure
- Head pressure/level sensing of elevated tanks and ground reservoirs
- Wastewater air-purge "bubbler system" pressure/level sensing
- Closed system process/pump control
- Telemetry system transducer/transmitter



## Model 221 Pressure Transducers (A300): Accurate, Stable Operation

Description	Part Number
221 GCE (1-5V output) transducer; 5# (2.3 kg), open	W3T4760
221 GCE (1-5V output) transducer; 15# (6.8 kg), open	W3T4761
221 GCE (1-5V output) transducer; 30# (13.6 kg), open	W3T4762
221 GCE (1-5V output) transducer; 75# (34.0 kg), open	W3T4763
221 GCE (1-5V output) transducer; 150# (68.0 kg), open	W3T4764
221 GCE (1-5V output) transducer; 200# (90.7 kg), open	W3T4765
221 GCE (1-5V output) transducer; 5#, (2.3 kg) N3X encl, gauge, valves	W3T5498
221 GCE (1-5V output) transducer; 15#, (6.8 kg) N3X encl, gauge, valves	W3T5499
221 GCE (1-5V output) transducer; 30#, (13.6 kg) N3X encl, gauge, valves	W3T5500
221 GCE (1-5V output) transducer; 75#, (34.0 kg) N3X encl, gauge, valves	W3T5501
221 GCE (1-5V output) transducer; 150#, (68.0 kg) N3X encl, gauge, valves	W3T5502
221 GCE (1-5V output) transducer; 200#, (90.7 kg) N3X encl, gauge, valves	W3T5503
221 GCD (4-20 mA output) transducer; 5#, (2.3 kg) open	W3T4817
221 GCD (4-20 mA output) transducer; 15#, (6.8 kg) open	W3T4818
221 GCD (4-20 mA output) transducer; 30#, (13.6 kg) open	W3T4819
221 GCD (4-20 mA output) transducer; 75#, (34.0 kg) open	W3T4820
221 GCD (4-20 mA output) transducer; 150#, (68.0 kg) open	W3T4821
221 GCD (4-20 mA output) transducer; 200#, (90.7 kg) open	W3T4822
221 GCD (4-20 mA output) transducer; 5#, (2.3 kg) N3X encl, gauge, valves	W3T4839
221 GCD (4-20 mA output) transducer; 15#, (6.8 kg) N3X encl, gauge, valves	W3T4840
221 GCD (4-20 mA output) transducer; 30#, (13.6 kg) N3X encl, gauge, valves	W3T4841
221 GCD (4-20 mA output) transducer; 75#, (34.0 kg) N3X encl, gauge, valves	W3T4842
221 GCD (4-20 mA output) transducer; 150#, (68.0 kg) N3X encl, gauge, valves	W3T4843
221 GCD (4-20 mA output) transducer; 200#, (90.7 kg) N3X encl, gauge, valves	W3T4844
221 GCI (120 VAC pwrld 4-20 out) transducer; 5#, (2.3 kg) N3X, gauge, valves	W3T5504
221 GCI (120 VAC pwrld 4-20 out) transducer; 15#, (6.8 kg) N3X, gauge, valves	W3T4845
221 GCI (120 VAC pwrld 4-20 out) transducer; 30#, (13.6 kg) N3X, gauge, valves	W3T4846
221 GCI (120 VAC pwrld 4-20 out) transducer; 75#, (34.0 kg) N3X, gauge, valves	W3T5505
221 GCI (120 VAC pwrld 4-20 out) transducer; 150#, (68.0 kg) N3X, gauge, valves	W3T4847
221 GCI (120 VAC pwrld 4-20 out) transducer; 200#, (90.7 kg) N3X, gauge, valves	W3T5506
Oil seal freeze protective assembly	W2T295024
NOTE: Pressure and drain fittings are 1/4" (0.64 cm) NPT.	

The Model 221 Pressure Transducer is offered in three variations to meet your specific requirements. They are:

### Model 221 GCD

15-40 VDC loop powered, 2-wire transmitter with 4-20 mA DC output signal. Requires 15-40 VDC loop power to drive up to a 0-1400 Ohm resistive load (meter, controller, circuit resistance). See Table 1 for loop power/load driving.

### Model 221 GCE

12 VDC powered (10.5-30 VDC) signal transducer with 1-5 VDC output. Capable of driving 100 Ohm or higher resistance load. Supply voltage variations are accommodated over a 10.5-30 VDC range with a 30 mA DC maximum current draw. This model is well suited to battery operation. Varistor/resistor/diode transient protection is provided.

### Model 221 GCI

120 VAC powered, 4-wire transmitter with 4-20 mA DC output signal; with loop powered by this unit. Provides 4-20 mA DC output signal to drive a 0-1000 Ohm resistive load. Signal output loop is powered by this unit at approximately 33 VDC. This model includes a Manual Model Switch and Pot as well as a 0-1mA or 0-1.999 VDC attenuable drive for an optional analog or digital panel meter or related control. Transient protection is provided on both the 120 VAC power and the 4-20 mA DC output signal circuits. Current draw is 10 VA or less.

### Complete Control Capabilities

Siemens Water Technologies offers a single, high-quality source for everything from simple level sensors to telemetry systems involving complex system control engineering and software. Based in Vadnais Heights, Minnesota, Control Systems is part of the Siemens Water Technologies leading global provider of industrial, municipal and residential water and wastewater treatment systems, products and services. As a major manufacturer/integrator with an extensive selection of specialized product lines in the areas of SCADA and telemetry, power equipment integration, automation and measurement, Control Systems is uniquely positioned to provide cost effective, comprehensive solutions for water, wastewater and process control and telemetry applications.

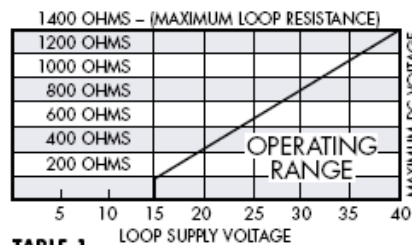

TABLE 1

App4Water

2 Forest Drive

Catonsville, MD 21228

410.744.9040 phone

410.744.6062 fax

www.app4water.com

© 2010 Siemens Water Technologies Corp.

CS-221dr-DS-0710

Subject to change without prior notice.

The information provided in this literature contains merely general descriptions or characteristics of performance which in actual case of use do not always apply as described or which may change as a result of further development of the products. An obligation to provide the respective characteristics shall only exist if expressly agreed in the terms of the contract.