



chlorinators incorporated

1044 SE Dixie Cutoff Road, Stuart, Florida 34994 USA

Phone: (772) 288-4854 Fax: (772) 287-3238

www.regalchlorinators.com Email: chlorinc@aol.com

REGAL GAS DETECTOR

Series 3000

The REGAL Series 3000 Gas Detector (Chlorine or Sulfur Dioxide) is a very important accessory item that should be part of ALL Regal Gas Feed System installations. The REGAL Series 3000 Gas Detector is a safety device that is as important as a gas mask or self contained breathing apparatus. It should not be deleted from the system solely on the basis that current regulations in a given geographical area do not specifically require this item.

A properly installed and calibrated REGAL Series 3000 Gas Detector can save lives and protect equipment and property from the effects of these gases by providing warning of gas leaks AS SOON AS THEY OCCUR. Properly installed, calibrated and maintained, REGAL Series 3000 Gas Detectors can accurately sense and display the presence of free Chlorine or free Sulfur Dioxide in the environment at levels below those mandated by OSHA and throughout the working life of the unit.

IMPORTANT NOTES AND WARNINGS

- All software including design, appearance, algorithms and source codes are copyrighted and owned by Chlorinators Incorporated.
- The entire contents of this manual **MUST** be read and understood prior to installing and operating this equipment.
- DO NOT** discard this instruction manual upon completion of the installation as this manual contains information essential to the safe handling, operation and maintenance of this equipment.
- Additional instruction manuals are available at nominal cost from Chlorinators Incorporated.
- Plastic pipe or tubing connector fittings may be broken or damaged if tightened excessively. **HAND TIGHTEN ONLY**.
- For maximum operation, the installation should be indoors so that the minimum and maximum temperature limitations as listed in the "**TECHNICAL SPECIFICATIONS**" section of this manual are not exceeded.
- This equipment is suitable for use only with the gases specified. **DO NOT USE THIS EQUIPMENT WITH OTHER GASES**. Such use can result in failures having hazardous consequences.
- To insure proper and safe operation of this equipment, use only REGAL parts. The use of non-REGAL parts can result in equipment failures having hazardous consequences and voids the REGAL warranty.
- Maintenance should be performed by qualified personnel familiar with this type of equipment, such as Chlorinators Incorporated themselves.
- It is essential that all external wiring be done exactly as shown on the diagrams depicted in this manual. Incorrect wiring or improper grounding of this equipment **WILL** cause improper operation and presents a safety hazard.
- Field wiring **MUST** conform to national and local electrical codes.
- Disconnect power **BEFORE** removing the cover or servicing this equipment.
- ALWAYS** make sure that the cover is in place and securely fastened to prevent the entry of moisture, water or corrosive gases and also to eliminate the potential for electrical shock.
- Any equipment powered by **AC** line voltage presents a potential shock hazard. Installation and servicing of this equipment should only be attempted by qualified electronics technicians.
- Damage to the circuit boards or internal components incurred by drilling the enclosure for field wiring or connecting power lines to low voltage signal terminals **VOIDS** the warranty.
- Ground **MUST** be provided as part of the installation.

CHLORINATORS INCORPORATED ONE (1) YEAR LIMITED WARRANTY

Chlorinators Incorporated (hereinafter called "C.I.") sets forth the following warranties with respect to its REGAL Series 3000 Gas Detector. This warranty does not apply to the purchase of spare parts or other services performed by C.I. or its authorized Dealers. This represents the entire agreement between C.I. and Buyer (also referred to as "end-user") and shall apply unless modified in writing and signed by a C.I. Officer, and this warranty and its intended terms shall supersede any prior negotiations, correspondence, understandings, or agreements, written or oral. The Buyer agrees to and accepts all terms of this warranty by its contracting for or acceptance of C.I.'s products, and forms or other documents or statements issued by Buyer or any other person shall not modify or otherwise affect any of the following terms. Buyer should be aware that reseller must rely entirely upon Chlorinators Incorporated's warranties, or assume their own responsibility.

The following states C.I.'s entire warranty and represents Buyer's exclusive remedy with respect to its product. Such warranties are expressly given in lieu of any other warranty, expressed or implied, including but not limited to those of merchantability and fitness for a particular purpose. This expressed warranty or any other warranty implied by law shall not cover defects due to accident, improper use, or non-compliance with C.I.'s operating and maintenance, assembly, installation manual and instructions.

Recommendations and advice as to specifications, capabilities, design, installation, engineering, application, and use of products are provided as an accommodation, and are intended only as suggestions. C.I. assumes no liability for such recommendations and advice, and they are not to be construed as constituting any warranty, expressed or implied.

TERM OF WARRANTY

C.I. warrants its REGAL Series 3000 Gas Detector for a period of one (1) year from date of shipment from C.I. Date of shipment from the factory shall be determined solely on the basis of the serial code affixed to the Gas Detector's enclosure. The serial number contains a date code. All serial numbers are also registered by Chlorinators Incorporated as to date of shipment, model number, accessories, options, and billing name. If the serial number is missing, defaced, changed, or in any way rendered unreadable, Chlorinators Incorporated shall, at its option, have the right to declare the warranty void. If the serial number does not match the registered model number as to, but not limited to, such items as accessories or options, the same shall apply.

The warranty shall apply against material defects in components and workmanship occurring in the course of manufacture. Buyer's sole remedy for breach of said warranty shall be, at C.I.'s option, either repair or replacement of any unit which is received by C.I. at its plant in Stuart, Florida (shipping charges prepaid by buyer), within the time period set forth above and which is found by C.I. to be defective by reason of manufacture.

Notwithstanding the foregoing, C.I. shall not be liable to Buyer for damages, including personal

injury or death to any person or persons, or claims of any kind by a third party or property damage, or loss of business or profits. In no event shall C.I. be liable to Buyer for consequential or accidental damages of any kind, even if C.I. was aware of the possibility of such damages. There are no remedies except those set forth. Further, that there are no other authorized warranty repair facilities other than those at the Chlorinators Incorporated factory in Stuart, Florida.

EXCLUSIONS

The following are considered external environmental factors beyond the control of C.I., and which may cause damage and/or need for service which will be specifically excluded from this warranty (i.e., not a material defect in components and workmanship occurring in the course of manufacture).

1. Damage by extraneous causes such as fire, water, lightning, chemical or galvanic attack, etc.
2. Damage to the circuit boards or internal components incurred by drilling the enclosure for field wiring.
3. Damage due to the connection of power lines to low voltage signal terminals.
4. Physical damage due to force, dropping, misuse or other abuse.
5. Use other than that as described in this Instruction Manual (misapplication).
6. Repair by someone other than Chlorinators Incorporated.
7. Improperly installed.
8. This warranty **DOES NOT** cover wear items subject to periodic replacement such as sensors, fuses, batteries, o-rings, gaskets, seals, packing, etc.

The exclusions listed above are provided for purposes of clarification, and are not intended to, in any way, limit or eliminate other possible exclusions.

NO OTHER WARRANTIES

Unless otherwise explicitly agreed in writing, and signed by a C.I. officer, it is understood that this is the only written warranty given by C.I. for the systems and components stated.

The dealers or representatives of C.I. may not make verbal representations that add, modify or change the written warranties contained herein or change the extent and nature of C.I.'s liability. In no event shall C.I. be liable for direct, consequential, special, incidental or punitive damages of any kind, with respect to the product, including but not limited to those which may allegedly arise out of breach of warranty, breach of contract, negligence, strict liability, or any other law, governmental regulation, or court decision, except as provided herein.

CONTENTS

1.0

GENERAL

2.0

MODEL NUMBER DESIGNATION

3.0

RELAY OPERATION

4.0

OPTIONAL BATTERY BACK-UP OPERATION

5.0

INSTALLATION

6.0

WIRING

7.0

START-UP AND OPERATION

8.0

SPECIFICATIONS

9.0

CALIBRATING THE DETECTOR (AUTOCAL)

10.0

SERIAL COMMUNICATIONS

11.0

SENSOR CROSS-SENSITIVITY DATA

IMPORTANT:

Please mail or fax this registration form to establish your warranty.

REGAL Registration Card

REGAL REGISTRATION CARD

IMPORTANT: To further establish your warranty and to enable us to contact you should the need arise, please fill out this card and return it promptly. Please do it now. Thank you.
Chlorinators Incorporated, Stuart, FL is the only authorized Warranty Repair facility for REGAL GAS DETECTORS/SMARTVALVES.

PLEASE PRINT, THANK YOU

Gas Detector/SMARTVALVE Serial No.(s)* 1. _____ 2. _____

*Serial No. plate located inside unit on the right

Purchased From _____

Your Name _____ Title _____

Organization _____

Mailing Address _____

City _____ State _____ Zip _____

Phone (_____) _____ Ext. _____

DRAWINGS

Drawing No. 1
Display/CPU Circuit Board #4100

Drawing No. 2
Power Supply/Relay Circuit Board #8300

Drawing No. 3
Typical Wiring Drawings –
Analog Output Circuit Board #8400
and Serial Communications
Output Circuit Boards #8500-1 and 8500-2

Drawing No. 4A
Typical Installation Drawing – 1 Sensor Detector

Drawing No. 4B
Typical Installation Drawing – 2 Sensor Detectors

Drawing No. 5
Detector Face Plates

Drawing No. 6
Typical Wiring Diagram Showing Detector Relay
Interfaced With Chlorine Room Exhaust Fan

Drawing No. 7
Connecting The REGAL VAC/AL-1 Remote Alarm
Horn/Light To The Detector Relays

Drawing No. 8
Sensor Replacement Drawing/Procedure

Drawing No. 9
Engineering Data Sheets – Enclosure Dimensions

IMPORTANT:

Fill out and mail or fax the form on the reverse side
to establish your warranty.



CHLORINATORS INCORPORATED
1044 SE Dixie Cutoff Road
Stuart, FL 34994-3436



1.0 GENERAL

REGAL Series 3000 Gas Detectors are designed for use wherever chlorine or sulfur dioxide is stored, distributed, or used in a process or any place where potential leakage of these gases would pose a risk to personnel, property and/or the environment.

Properly installed, calibrated, and maintained, REGAL Series 3000 Gas Detectors can accurately detect and display the presence of free chlorine or free sulfur dioxide in the environment at levels below those mandated by OSHA throughout the working life of the sensor(s) used.

The basic system includes a wall mounted monitor with one or two remote wall mounted sensors. Sensors are furnished as standard with 25' length of cable. Cable lengths can be extended up to 1,000'.

The front cover of the REGAL Series 3000 Gas Detector includes the following displays:

- A three digit "**Numeric Display**" to indicate instantaneous gas concentration in mg/l (PPM). On dual sensor units, the numeric display alternates in presenting the gas concentration of each sensor as indicated by the arrow-head LED indicator at the bottom of each bargraph.
- Separate LEDs to indicate which gas (chlorine or sulfur dioxide) is being monitored.
- A twelve LED four color "**Bargraph**" that mimics the numeric display and indicates alarm event conditions via WARNING and DANGER LEDs. The highest bargraph LED activated during a leak event remains latched (requiring a manual reset) even as the gas concentration decreases. This safety feature indicates the approximate magnitude of the leak even if the display returns to zero. Dual sensor gas detectors have two bargraphs.
- A "**Battery**" LED lights whenever the unit is being operated from the OPTIONAL Battery Back-Up.
- A "**Program**" LED lights when the unit is in the Program Mode.
- An "**Alarm Disable**" LED lights to provide an indication that the alarm relays have been disabled for a "timed 15-minute period." This feature allows the user to perform operational tests of the sensor(s) without setting off external alarms.

- A "**Latch**" LED lights whenever the internal (user adjustable) latch relay timer causes the WARNING and/or the Latch Relay to activate thereby requiring a manual reset after the alarm condition is cleared.
- A four button "**Keypad**" is included for all operator normal and programming functions.

REGAL Series 3000 Gas Detectors include six relay circuits (2 Warning, 2 Danger, 1 Horn/Failure and 1 Latch). The two **WARNING** relays, the **LATCH** relay and the **HORN/FAILURE** relay are SPDT. The two **DANGER** relays are DPDT. All relays are rated at 10 Amps @ 250 VAC, 50 or 60 Hz.

All single sensor detectors include a single, isolated and unpowered 4-20 mA DC analog output circuit board (**8400-3**). All dual sensor detectors include a dual, isolated and unpowered 4-20 mA DC analog output circuit board (**8400-4**). Power for the analog output loop is accomplished using a DC Power Supply not furnished by Chlorinators Incorporated. The Power Supply can be 12 VDC minimum to 30 VDC maximum. 12 or 24 VDC Power Supplies are fairly common and can be purchased from many sources. A 12 VDC Power Supply allows the analog output signal to transmit into a maximum of 300 Ohms resistance with no signal loss while a 24 VDC Power Supply can transmit into 900 Ohms of resistance.

AVAILABLE OPTIONS INCLUDE:

- Battery Back-Up. The battery has the ability to power the detector for up to a day.
- A Serial Communications Output Circuit Board. This option is available in either RS232 (**#8500-1**) or RS485 (**#8500-2**) interface standards. Either board can be programmed to communicate in either OPTO-22 or MODBUS compatible protocol. This circuit can also output in a continuous send mode of gas concentration for data logging.

2.0 MODEL NUMBER DESIGNATION

The Model Number “blanks” MUST be filled in completely in order to assure the correct detector and options will be furnished.

MODEL 300 - -

INDICATES

1 = Single Sensor CL₂

2 = Dual Sensor CL₂

3 = Single Sensor SO₂

4 = Dual Sensor SO₂

5 = Dual Sensor CL₂ & SO₂

INDICATES

C = RS232 Serial Communications output circuit board (#8500-1).

D = RS485 Serial Communications output circuit board (#8500-2).

E = Battery Back-Up.

3.0 RELAY OPERATION

The **WARNING** relays activate at 1 PPM for chlorine and at 2 PPM for sulfur dioxide leak events. The **DANGER** relays activate at 3 PPM for chlorine and at 5 PPM for sulfur dioxide leak events. On a single sensor detector, both **WARNING** relays and both **DANGER** relays activate during an appropriate alarm event. On a dual sensor detector, one **WARNING** and one **DANGER** relay is dedicated to each sensor.

All remote alarm devices connected to the **HORN/FAILURE** relay can be silenced (turned off) during an alarm event using the **SILENCE** keypad button. All remote alarm devices connected to the **LATCH** relay WILL NOT activate until the latch time as set by the operator is reached unless overridden by a **DANGER** event. All relays except for the **HORN/FAILURE** relay can be set for normal or failsafe operation.

4.0 OPTIONAL BATTERY BACK-UP OPERATION

When the OPTIONAL Battery Back-Up is used, the unit will continue to operate during AC power outages. During the outage, all front panel displays are turned off except for the “**BATTERY**” LED to conserve battery life. If the user wishes to view the monitor displays during the power outage, he can turn on the displays for approximately 10 seconds (20 seconds for dual sensor monitors) by pressing **ANY** keypad button.

A charging circuit in the monitor keeps the battery in a fully charged ready state. If the battery voltage degrades to between 10.5 and 8.5 Volts while under battery power, the “**BATTERY**” LED “blinks.” If battery voltage degrades to less than 8.5 Volts, the REGAL Gas Detector is shut off and the battery **MUST** be charged or replaced. The monitor may have to be reset by turning the AC power off then on, after the battery drops below 8.5 Volts.

Life expectancy of the battery is about 3 years before a normal cell failure occurs. The battery has the capacity to power the monitor for up to one day.

5.0 INSTALLATION (See Drawing #4)

The gas sensor(s) are connected to the monitor with 25' of cable when shipped from the factory. If the sensor(s) must be disconnected from the monitor in order to route the cable through a wall for instance, be sure to observe correct polarity of the signal line when reconnecting the cable to the monitor terminals. SEE DRAWING #1.

The monitor enclosure is designed for wall mounting at eye level to an inside wall in order to assure that the temperature limitations (SEE SPECIFICATIONS) ARE NOT exceeded. If the monitor **MUST** be mounted outdoors, it should not be installed in direct sunlight as this makes it difficult to see the displays. Protect the unit from moisture due to condensation, splashing, hose sprays and rain.

- 5.1 Remove the front cover from the monitor enclosure by unscrewing (counter clockwise) the four corner screws.
- 5.2 Mount the monitor enclosure to the wall with four screws inserted into the corner openings that the cover screws were removed from.
- 5.3 The gas sensor(s) mount to the wall using two screws through the tab openings on each side of the sensor enclosure.

IMPORTANT: SENSOR LOCATIONS MUST BE CAREFULLY CHOSEN TO ASSURE A GAS LEAK WILL BE DETECTED AS SOON AS IT OCCURS. THE FOLLOWING MUST ALSO BE TAKEN INTO CONSIDERATION.

1. ALWAYS MOUNT THE SENSOR WITH THE OPENING POINTING DOWNWARDS.
2. MOST SENSORS RESPOND TO GASES OTHER THAN THOSE THEY ARE DESIGNED FOR SO CARE IS NECESSARY TO ASSURE INTERFERENT GASES ARE NOT PRESENT IN AREAS WHERE THE SENSORS ARE TO BE MOUNTED.
3. FOR GASES HEAVIER THAN AIR, SENSORS SHOULD BE INSTALLED A MAXIMUM OF 18" (PREFERABLE 6") ABOVE FLOOR LEVEL. FOR GASES LIGHTER THAN AIR, SENSORS SHOULD BE INSTALLED AT A LEVEL HIGHER THAN THE GAS CONTAINER AND/OR THE GAS FEED SYSTEM COMPONENTS.
4. AVOID WATER. DROPLETS ADHERING TO THE SENSOR MEMBRANE WILL REDUCE OR NEGATE SENSOR PERFORMANCE.
5. MOUNTING THE GAS SENSORS NEAR POWER TRANSFORMERS OR OTHER STRONG ELECTROMAGNETIC FIELDS MAY CAUSE UNDESIRABLE RESULTS.
6. RAPID AIR FLOW PAST A SENSOR'S OPENING (TYPICALLY GREATER THAN 1 LITER PER MINUTE) CAN CHANGE GAS DIFFUSION CHARACTERISTICS WHICH CAN AFFECT SENSOR PERFORMANCE RESULTING IN INACCURATE MEASUREMENT. IN ADDITION, HIGH AIR VELOCITIES CAN REDUCE SENSOR LIFETIME BY DRYING OUT THE SENSOR MORE RAPIDLY THAN NORMAL.

5.4 The sensor membrane is protected during shipment by an o-ring sealed calibration plug with two (2) cap seals. **CALIBRATION PLUG(S) MUST BE REMOVED AFTER INSTALLATION AND FOR PROPER OPERATION.** Keep this plug for possible future calibration purposes.

5.5 If the Battery Back-Up option is provided, it is mounted on the wall next to and within 5' of the monitor enclosure.

5.5.1 Remove the battery enclosure cover by removing the four corner screws.

5.5.2 Mount the battery enclosure to the wall using four screws inserted into the cover screw hole openings.

5.5.3 Route the battery cable through the cable grip on the bottom of the monitor enclosure.

5.5.4 In the monitor enclosure, connect the RED battery cable wire to the "+" terminal and the BLACK battery cable wire to the "-" terminal of terminal block TB4 located on the Display/CPU Circuit Board. SEE DRAWING #1.

IMPORTANT: DO NOT MAKE THE CONNECTION STATED IN 5.5.5 UNTIL THE SERIES 3000 GAS DETECTOR IS OPERATING ON 120 VOLT, AC POWER.

5.5.5 In the battery enclosure, connect the spade connector on the end of the RED wire to the RED "+" spade connector of the battery.

5.5.6 Replace the battery enclosure cover.

6.0 WIRING (See Drawings #1, #2 and #3)

The Sensor(s) are connected to the monitor when shipped from Chlorinators Incorporated. A six (6) foot AC power cord is connected to the appropriate terminals on Power Supply Circuit Board #8300. SEE DRAWING #2.

NOTES:

1. All wiring terminations to the alarm relays are via plug in socket connectors for ease of wiring and to prevent damage to the printed circuit board.
2. Chlorinators Incorporated has designed state-of-the-art voltage surge suppressor components into the electrical circuitry of each electronic device we manufacture. These internal components provide a last line of defense to absorb electrical surges and spikes (in most cases) before they cause irreparable damage. If the surge suppressors are sacrificed while protecting the equipment, **THEY HAVE DONE THEIR JOB.**

For the best possible protection, **EXTERNAL** surge suppression devices (**SUPPLIED BY OTHERS**) should be a normal part of all electronic component installations. These should be placed on all incoming AC power circuits and where applicable, on all incoming DC signal lines as well. These devices **MUST** be chosen and sized properly (particularly those used on 4-20 mA DC signal lines) to assure maximum protection and to make sure the suppressor itself does not overload the line resulting in loss of signal. **CONSULT CHLORINATORS INCORPORATED AS NECESSARY.**

3. If the gas detector was ordered with the OPTIONAL Back-Up Battery, a fitting for connection of the battery cable to Terminal "TB4" of Display/CPU Circuit Board #4100 is also provided. SEE DRAWING #1. **BE SURE TO OBSERVE CORRECT POLARITY WHEN CONNECTING THE BATTERY.**

DO NOT plug in the battery until the gas detector is turned on and operating.

- 6.1 For a dual sensor detector, WARNING relay (RL4) and DANGER relay (RL1) are dedicated to sensor #1, and WARNING relay (RL5) and DANGER relay (RL3) are dedicated to sensor #2.

External alarm devices (audible or visual) are BY OTHERS and should be field connected to the relay circuits of the REGAL Series 3000 Gas Detector by qualified electricians conforming to all appropriate electrical codes.

7.0 START-UP AND OPERATION

On the back of Display/CPU Circuit Board #4100 is a four (4) position DIP Switch which is used to make the following selections.

- A. Switch Position #1 sets the condition of the internal Horn and the Horn Relay. **FACTORY SETTING IS OFF.**
- When in the **OFF** position, the Horn and Horn Relay are on continuously until **SILENCED** or **RESET**.
 - When in the **ON** position, the Horn and Horn Relay "pulse" until **SILENCED** or **RESET**.
- B. Switch Position #2 is for calibrating the Series 3000 Gas Detector (AUTOCAL). **FACTORY SETTING IS OFF.**
- When in the **OFF** position, calibration functions are disabled.
 - When in the **ON** position, calibration functions are enabled.
- C. Switch Position #3. **FACTORY SETTING IS OFF.**
- OFF** sets the relays for **NORMAL** operation.
 - ON** sets the relays for **FAILSAFE** operation.
- D. Switch Position #4. This switch allows the setting of Serial Communications Protocol and is only active when Serial Communications Circuit Board #8500 is installed. **FACTORY SETTING IS OFF.** If switch position #4 is ON, communications protocol setting (choice) is the last item in the Program Mode list (See 7.6).

- 7.1 Turn on the AC power circuit supplying power to the gas monitor.

IMPORTANT: WHEN THE UNIT IS TURNED ON, ALL LEDs AND DISPLAYS LIGHT AND ALL ALARM CIRCUITS ARE DISPLAYED FOR APPROXIMATELY 1 MINUTE TO ALLOW THE ELECTRONICS AND SENSOR(S) TIME TO STABILIZE. AT THE END OF THIS TIME, THE UNIT AUTOMATICALLY BEGINS THE PROCESS OF SCANNING, DISPLAYING AND TRANSMITTING READINGS AND ALARM CONDITIONS FOR THE ACTIVE SENSORS.

- 7.2 Remove the front cover of the gas detector enclosure and turn on the power switch located on the power supply circuit board. Alarms are automatically disabled for approximately 1 minute after startup.

If the operator or user of the system wishes to change any of the "Programming Mode" Factory Settings, he can do so at this time. To change factory settings and to set ALARM RELAY "LATCH" TIME(S), you must enter the "Programming Mode" by simultaneously pressing the "NEXT" and "ENTER" keypad button which turns on the "PROGRAM" indicator and the "ALARM DISABLE" indicator.

NOTE: While in the Programming Mode, the unit ceases normal operations; however, at any point in the programming process you can exit back into the normal operating mode by pressing and holding down the "NEXT" and "ENTER" keypad button.

While in the Program Mode, you can skip any of the following parameters, leaving the current setting unchanged by pressing the "NEXT" keypad button.

KEYPAD BUTTONS **MUST** BE HELD DOWN FOR AT LEAST 1/2 SECOND

The digital display indicates "dis" (Disable).

This parameter allows the operator to check the worthiness of the sensor(s) WITHOUT activating external alarms for a timed 15-minute period. **SEE MORE ABOUT CALIBRATING IN ANOTHER SECTION OF THIS MANUAL.**

- 7.3 Selecting "dis" disables the alarm relays for 15 minutes then automatically enables them again.

Selecting "en" (Enable) keeps the alarm relays active.

- 7.3.1 Press the UP or Down Arrow buttons to scroll between "dis" and "en."

- 7.3.2 Press "ENTER" to accept your selection and the next parameter "rly" is displayed.

7.4 “rly” = Relay Test. This parameter runs through a sequential test cycle of all alarm relays. Initiating this test takes you to the Operating Mode when complete.

Press “**ENTER**” to run through a test cycle of all alarm relays which when complete automatically takes you back into the **OPERATING MODE** or press “**NEXT**” to proceed to the LATCH Time Setting (SEE 7.5 BELOW).

7.5 The **LATCH** LED is lit and the digital display shows 0. This parameter allows you to set a delay **LATCH** time for the WARNING alarm and the latch relay. The **LATCH** LED is now on and the digital display is showing the delay time setting for the first sensor in seconds before the WARNING alarm relays become latched into the alarm state.

Press the “**UP**” or “**DOWN**” arrow buttons as necessary to set the delay time (adjustable between 0 and 240 seconds). **Factory setting is 0**. A setting of 0 **turns off** warning alarm latching.

Press “**ENTER**” to accept your selection.

NOTE: On dual sensor units, the above step will be repeated for the second sensor. The bargraph “arrow” indicators will show the sensor the setting is applied to.

7.6 When the OPTIONAL Serial Communications Board is installed, communication protocol options can be selected. Options are:

- 7.6.1 CP0: No serial communications. With this selection, the device will not speak or respond.
- 7.6.2 CP1: Continuous send for data logging.
- 7.6.3 CP2: OPTO-22 Protocol selected.
- 7.6.4 CP3s: MODBUS (ascii) Protocol selected.

8.0 SPECIFICATIONS

- 8.1 **Power Supply:**
Input: 100-250 VAC 50/60 Hz. @ 0.6A peak.
Inrush Current: 20A @ 115 VAC, 40A @ 230 VAC.
Output: +15V @ 1.7A current limited.
- 8.2 **Fuse Protection:**
2.5 Amps (250 V) for 120 VAC or 240 VAC.
- 8.3 **Input Capability:**
1 or 2 Sensors. Must be specified at purchase.
- 8.4 **Sensor Scan Display Rate:**
Approximate five (5) second intervals.
- 8.5 **Sensor Signal:**
4-20 mA, DC
- 8.6 **Sensor Full Scale Response:**
For Chlorine - 10 PPM
For Sulfur Dioxide - 20 PPM
- 8.7 **Resolution:**
For Chlorine - 0.1 PPM
For Sulfur Dioxide - 0.5 PPM
- 8.8 **Repeatability:**
±5%
- 8.9 **Operating Temperature:**
0-50°C (32-120°F).
- 8.10 **Horn:**
Internal 95 db.
- 8.11 **Relays:**
Warning, Horn/Failure and Latch relays are Single Pole, Double Throw (SPDT).
Danger relays are Double Pole, Double Throw (DPDT).
All relays are rated @ 10 Amps @ 250 VAC, 50 or 60 Hz.
All relays EXCEPT for the Horn/Failure relay can be configured for either normal or failsafe operation.
- 8.12 **Delay Timer for WARNING Relays and the Latch Relay:**
Adjustable from 0-240 seconds.
- 8.13 **Analog Output:**
A single isolated and unpowered 4-20 mA, DC Output Circuit Board is standard on all single sensor detectors.
A dual isolated and unpowered 4-20 mA, DC Output Circuit Board is standard on all dual sensor detectors.
NOTE: Analog Outputs require a 12 VDC minimum to 30 VDC maximum power supply not provided by Chlorinators Incorporated.

- 8.14 **Battery Back-Up (OPTIONAL):**
12 Volt, 1.1 AH, Lead Acid, gel cell.
- 8.15 **Operating Humidity:**
0-99% Non-Condensing.
- 8.16 **Monitor Enclosure:**
Wall Mounted Polycarbonate NEMA 4X
(7.87" x 7.87" x 5.25").
- 8.17 **Sensor Enclosure:**
Wall Mounted, Watertight, UL Approved
(4.0" x 4.0" x 2.5").
- 8.18 **Serial Communications (OPTIONAL):**
RS232 or RS485 using OPTO-22 or MODBUS
(ASCII) Protocol or, continuous send for data logging.
BAUD Rate: 1200-115,200.
- 8.19 **Cable Lengths:**
(Based on using 22 gauge, 2-conductor shielded cable)
Sensor Cable Length - 25' Standard. Can be
extended up to 1000'.
Battery Cable Length - 5'.
- 8.20 **Warning/Danger Alarm Points:**
For Chlorine - 1 PPM/3 PPM
For Sulfur Dioxide - 2 PPM/5 PPM

- 9.1.1 Pour approximately 1/4 to 1/2 ounce of
CLOROX into a paper cup or similar container.
- 9.1.2 Pour approximately 1/4 to 1/2 ounce of
Vinegar into the same container with the
CLOROX.
- 9.1.3 Swirl the CLOROX/Vinegar solution under the
sensor opening.

The small quantity of chlorine gas created should
almost immediately set off the detectors internal
alarm horn and activate all alarm relays. DISCARD
THE USED CLOROX/VINEGAR SOLUTION USING
APPROVED PROCEDURES.

- 9.2 To check sulfur dioxide sensors, (USE APPROPRIATE
SAFETY EQUIPMENT SUCH AS GLOVES,
APRON, EYE PROTECTION, ETC.);

NOTE: If external alarm activation during the test is a
problem, selecting "dis" (disable) in the Program Mode
(SEE PARAGRAPHS 7.2 AND 7.3 IN THIS MANUAL) will
disable all alarm relays for 15 minutes, then automatically
enable them again.

- 9.2.1 Connect a cylinder of sulfur dioxide calibration
gas to the sensor to be calibrated and turn on
for a few minutes to make sure the sensor
responds and alarms.

- 9.3 **IF REGULATIONS OR PERSONAL PREFERENCE
DICTATE A NEED TO CALIBRATE THE REGAL
SERIES 3000 GAS DETECTOR, PROCEED AS
FOLLOWS.**

NOTE: Alarm relays are automatically disabled during
AUTOCAL. For best results, follow this procedure in detail.

To calibrate a REGAL Series 3000 Gas Detector you **MUST**
have the shipping/calibration plug originally furnished with
the unit and a fresh cylinder of calibration gas equal to the
span value of the detector (10PPM for Chlorine detectors
and 20 PPM for Sulfur Dioxide detectors).

- 9.3.1 Turn **OFF** AC power to the gas detector, then
remove the front cover from the monitor to
gain access to the four position DIP Switch.
- 9.3.2 **CLOSE** Position #2 of the DIP Switch to
activate the **AUTOCAL** program, then reinstall
the front cover and turn **ON** the AC power circuit.
- 9.3.3 Wait until the detector electronics and sensor
have stabilized and a 0.00 mg/l (PPM) indication
is presented on the numeric display. This takes
approximately 1 minute.

9.0 CALIBRATING THE DETECTOR (AUTOCAL)

The electrochemical sensors used in REGAL Series 3000
Gas Detectors have proven themselves historically to be
relatively stable for at least one year of service and in many
cases, over the full two-year life expectancy of the sensor(s).
In most cases, it is unnecessary to calibrate the sensors
during this time period unless regulations or personal
preferences dictate otherwise.

It is, however, suggested that the sensors be periodically
checked to assure they have not reached their end of life
and that they are still capable of responding to gas leaks.

- 9.1 To check chlorine sensors, (USE APPROPRIATE
SAFETY EQUIPMENT SUCH AS GLOVES,
APRON, EYE PROTECTION, ETC.);

NOTE: If external alarm activation during the test is a
problem, selecting "dis" (disable) in the Program Mode
(SEE PARAGRAPHS 7.2 AND 7.3 IN THIS MANUAL) will
disable all alarm relays for 15 minutes, then automatically
enable them again.

10.0 SERIAL COMMUNICATIONS

REGAL offers a choice of two interface standards, RS232 or RS485.

RS232 employs unbalanced voltage signals and is generally limited to a speed of 20 Kbps (kilobits per second) and a distance of 50'. Because the transmission method is single ended, or unbalanced, it is susceptible to EMI and other electrical noise in the environment. Communication can be full duplex.

RS485 uses a balanced or differential voltage signal. RS485 uses only two conductors for both transmit and receive and is capable of data rates up to 115 Kbps at distances up to 4000'. Up to 64 devices can be connected and addressed in multi-point applications through a single port. The differential voltage transmission method reduces its susceptibility to electrical noise. Since only two conductors are used, communication is limited to half-duplex.

When the OPTIONAL Serial Communications Circuit Board #8500 is provided (RS232 or RS485), the REGAL device communicates using either OPTO-22 or MODBUS (ASCII) protocol. User must select which protocol standard is to be used (See Paragraph 7.6). Communication protocol uses:

8 data bits, no parity, 1 stop bit and NO handshaking

or

7 data bits, no parity, 2 stop bits and NO handshaking

10.1 In the CONTINUOUS SEND mode, (**CP1 Selected**), the REGAL device sends current values every few seconds in the following format:

SENSOR #	VALUE	UNITS	END
X:	XXXX.X	XXX	CRLF (ASCII 10/13)

The **sensor number** (1 or 2) is sent even in a single sensor unit and is followed by a colon (:). The **value** is always a 6-character string padded with leading zeros. Four digits to the left of the decimal point and one "tenths" digit. This maintains congruity with other REGAL monitoring devices.

The message is ended with a carriage-return/line-feed combo (ASCII 10/13). On dual sensor units, values are sent alternately as separate messages.

9.3.4 When the sensor to be calibrated is active as indicated by a lit bargraph "arrow" LED, simultaneously press the **SILENCE** and **ENTER** keypad buttons. The monitor locks on that sensor and the numeric display should indicate "**CAL**" for calibrate.

9.3.5 Connect the hose from the pressure regulating valve on top of the cylinder of calibration gas to one of the shipping/calibration plug ports. The other port remains open to atmosphere.

9.3.6 Carefully insert the shipping/calibration plug with hose attached into the sensor opening to be calibrated.

9.3.7 Open the valve on the cylinder of calibration gas and wait the appropriate time interval (usually 5 minutes) to make sure the sensor is saturated. At this point, the "**CAL**" indication should have changed to the actual PPM value the sensor is capable of transmitting based on the calibration gas value the sensor is receiving.

NOTE: If the "**CAL**" indication remains, the sensor has degraded to less than 50% and is in immediate need of replacement.

9.3.8 Press the **ENTER** keypad button to calibrate the detector and you are automatically back in the operating mode. The next scan cycle of the calibrated sensor should produce an indicated value of at least 9.90 PPM to indicate calibration was successful.

9.3.9 Close the valve on the calibration gas cylinder and remove the shipping/calibration plug from the sensor opening, then wait until the sensor purges itself of gas and the displayed value has returned to 0.00 mg/l (PPM).

9.3.10 If calibrating additional sensors, repeat this procedure for each sensor.

NOTE: If a mistake is made while calibrating, you can again enter the calibration program and when the sensor being calibrated is active, press the **RESET** keypad button. This will restore the original factory calibration values.

9.3.11 To prevent accidental calibration when no calibration gas is applied to the sensor, turn **OFF** AC power to the detector, remove the front cover, and **OPEN** Position #2 of the DIP Switch, then install the front cover and turn **ON** the AC power circuit.

IMPORTANT:

1. IF OPTO-22 PROTOCOL IS TO BE USED, FOLLOW INSTRUCTIONS OUTLINED IN PARAGRAPH 10.2 BELOW.
 2. IF MODBUS (ASCII) PROTOCOL IS TO BE USED, FOLLOW INSTRUCTIONS OUTLINED IN PARAGRAPH 10.3 BELOW.
-

10.2 When CP2 (OPTO-22) is selected, the REGAL

communications protocol. OPTO-22 is a half-duplex, poll and respond protocol. The monitor waits for a command message then responds with a return message.

Command messages take the following format:

START	ADDRESS	COMMAND	DATA	CHECKSUM (ASCII-HEX)	END
(>)	XX	X	XX	XX	CR

The **start of message** character is always the greater-than symbol (>). Any message without this start character will be ignored.

The **address** is a 2 digit ASCII-hex value assigned to the individual monitor. All messages without the correct address will be ignored. Valid digits are 0-9 and A-F, lower case a-f are not allowed. The valid address range is 00-FF. Two characters are always required even if the first is 0. This applies to the data and checksum fields as well.

The **command** is always one character and IS case sensitive. The REGAL device recognizes only the five commands below. Any other characters will return a nak (N).

1. Requests the value from sensor #1.
2. Requests the value from sensor #2.
3. Sets the monitor's internal network address to the 2 digit ASCII-hex value contained in the data field. For this command, the data field must meet the same restrictions as the address field above. If the data field is not valid, a nak (N) is returned.

Default Address = 7F

4. Sets the communication baud rate using a two digit identifier in the data field as follows:
01 = 1200, 02 = 2400, 03 = 4800, 04 = 9600,
05 = 19.2k, 06 = 28.8k, 07 = 36.4k, 08 = 57.6k,
09 = 115.2k

Default Baud Rate = 1200

- B. Request Product ID.

IMPORTANT: LONG DISTANCES BETWEEN INDIVIDUAL COMPONENTS WILL REQUIRE LOWER BAUD RATES TO COMMUNICATE PROPERLY. THIS MUST BE DETERMINED ON A JOB-BY-JOB BASIS.

Response (server) msg:

N (nak) ascii-hex error code

NAK	ERROR	END
N	XX	CR

A (ack)

ACK	RET VALUE	(OPT) UNITS	CHECKSUM	END
A	XX (XX...)	XXX	XX	CR

Commands: 1, 2, 3, 4, B

- 1 (read side 1) no value
- 2 (read side 2) no value
- 3 (set address) value = ascii-hex address in range 01h-F7h
- 4 (set baud) value = ascii-hex baud code
- B (product ID) no value

Command Examples:

1 (2) (read side 1 (2)): return value is 4 character 2 byte ascii-hex value, followed by a 3 character units string.

EXAMPLE: >7F1AE(CR) sent to a detector with a 10 PPM leak at address 7F would return the value of sensor 1 as A00APPMBD(CR). The returned value is 000A hex, that is 10 decimal, in units of PPM. The checksum is BD hex, 189 decimal.

3 (set network address): return value is 2 character 1 byte ascii-hex value.

EXAMPLE: >7F32B24(CR) sent to the gas detector monitor at address 7F would change its network address to 2B and return the new address for verification as A2B74(CR). The checksum is 74 hex, 116 decimal.

4 (set baud rate): return value is 2 character 1 byte ascii-hex value.

EXAMPLE: >7F40112(CR) sent to the gas detector monitor at address 7F would change its baud rate to 1200 after returning the value for verification as A0161(CR). The value, in both the command and return messages, is always a 2 character ascii-hex value even though the first character is always 0. The checksum is 61 hex, 97 decimal.

B (request product ID): return value is 26 character string.

EXAMPLE: >7FBBF(CR) sent to a single sensor SO₂ leak detector at address 7F would return AREGAL3003XFXXX V1.15D2(CR). The model number string is always 16 characters even if trailing spaces exist. The checksum is D2 hex, 210 decimal.

In addition to the carriage-return (ASCII 13) as an end of message character, REGAL devices also recognize the line-feed (ASCII 10) and period (.) for OPTO-22 compatibility.

Return messages are either an ack (A) or nak (N). If an error occurs, a nak (N) is returned followed by an error code and a carriage-return (ASCII 13). In this case, the command was not processed. If the command was successfully processed, an ack (A) is returned. The new address or baud rate will then be required for any subsequent communications.

TO RESET DEFAULTS

1. Turn **OFF** the Gas Detector ON/OFF Switch.
2. Unplug Serial Communications Circuit Board #8500.
3. Turn **ON** the Gas Detector ON/OFF Switch.
4. After the unit stabilizes, press RESET and NEXT keypad buttons and wait for “**rdy**” (ready) message.
5. Turn **OFF** the Gas Detector ON/OFF Switch.
6. Plug in Serial Communications Circuit Board #8500.
7. Turn **ON** the Gas Detector ON/OFF Switch.

10.2.1 CHECKSUM EXPLANATION

This is an error checking field used to verify that the message received by the REGAL device matches that sent by the Master control. It is always a two-character representation of a hexadecimal value. Allowable characters are in the range “0” - “9”, “A” - “F”, or the question mark “?” (ASCII 3FH).

The checksum is calculated by adding the ASCII values of all the characters in the message excluding the Start-of-Message character, the End-of-Message character and the checksum field. The sum is then divided by 100H (256 decimal). The remainder from the division is the checksum value. The checksum may be ignored for an individual command message by placing “??” in this field. This is included in the specification for trouble shooting purposes and is not recommended for normal operation.

10.2.2 ERROR CODES

If an error is detected by the REGAL device, it will respond with the NAK character (N) followed by one of the error codes in the list below. No checksum will accompany the error message. No messages should be returned from the Master control in response to errors, nor should the Master report any errors it detects to the REGAL Slave device. If necessary the command

should be repeated. If any of these errors occurs, the command will not be executed.

REGAL devices may return the following error codes:

01 Undefined Command

The command character was not recognized as one of the characters in the command set of the specific REGAL device.

02 Checksum Error

The checksum received by the REGAL device was not equal to the internal checksum calculated from the message.

03 Input Buffer Overrun

The message received exceeded the maximum number of characters allowed for a command by the REGAL device.

04 Non-Printable or Disallowed Character Received

The message received contained characters outside the ASCII range of 21 (33 decimal "!") to 7EH (126 decimal "~") allowed by OPTO-22 devices.

05 Data Field Error

The message received by the REGAL device was too short.

06 Invalid Data

The data field was outside the range allowed for the specified command.

07 Unknown Error

The REGAL device detected an internal error while executing the command.

10.3 When CP3 (MODBUS (ascii)) is selected, MODBUS uses LRC (Longitudinal Redundancy Check) instead of checksum. This value is a slightly modified checksum. (FFh-checksum) + 1. The start character is always the colon (:) and the end character is always the carriage-return/line-feed (CRLF) combination.

NOTE: What is called a command in OPTO-22 is called a function in MODBUS.

Error Codes:

01: Illegal Function. The function code received was not in the recognized list.

03: Illegal data value. The data value received was not in the acceptable range for the function.

04: Slave device failure. An internal error occurred while processing the request.

- Functions: 41, 42, 43, 44, 2B
 41 (read side 1) no value
 42 (read side 2) no value
 43 (set address) value = ascii-hex address
 44 (set baud) value = ascii-hex baud code
 2B (product ID) no value

Functions 41-44: REGAL monitor defined functions

Function request (client) msg:

START	ADDRESS	FUNCTION	(OPT) VAL	LRC	END
:	XX	XX	XX	XX	CRLF

Response (server) msg: All MODBUS responses include the start character and the address for verification.

Error: Along with the ascii-hex error code, MODBUS adds 80 hex, 128 decimal, (sets most significant bit) to the function code to alert the client that an error has occurred.

START	ADDRESS	FUNC+80h	ERROR	LRC	END
:	XX	XX	XX	XX	CRLF

The MODBUS spec defines other error codes but only the above are used by REGAL monitors. No error msg is returned for communication errors, such as checksum or time-out. The client should simply time-out and try again if there is no response.

Normal response:

START	ADDRESS	FUNCTION	BYTE COUNT
:	XX	XX	XX
RET VALUE	(OPT) UNITS	LRC	END
XX (XX)	XXX	XX	CRLF

Function Examples:

41 (42) (read side 1 (2)): return value is 4 character 2 byte ascii-hex value, followed by a 3 character units string.

EXAMPLE: :7F411E(CRLF) sent to a gas detector with a 10 PPM leak at address 7F would return the value of sensor 1 as :7F4107000APPMF9(CRLF). The returned value is 000A hex, 10 decimal, in units of PPM. The LRC is F9 hex, 249 decimal. The byte count field holds the number, in ascii-hex, of bytes in the data field(s) to read before the LRC. In this case, 07.

43 (set network address): return value is 2 character 1 byte ascii-hex value.

EXAMPLE: :7F432BA8(CRLF) sent to any gas detector monitor at address 7F would change its network address to 2B and return the new address for verification as :7F43022B46(CRLF). The LRC is 58 hex, 88 decimal. The address field still holds the old address, but the data field holds the new address. All subsequent requests must be made to the new address. The byte count field is 02.

44 (set baud rate): return value is 2 character 1 byte ascii-hex value.

The two digit baud rate identifier choices are:

- 01 = 1200, 02 = 2400, 03 = 4800, 04 = 9600,
- 05 = 19.2k, 06 = 28.8k, 07 = 36.4k, 08 = 57.6k,
- 09 = 115.2k

Default Baud Rate = 1200

EXAMPLE: :7F4401BA(CRLF) sent to any gas detector monitor at address 7F would change its baud rate to 1200 after returning the value for verification as :7F440201A8(CRLF). The value, in both the command and return messages, is always a 2 character ascii-hex value even though the first character is always 0. The LRC is A8 hex, 168 decimal. The byte count field is 02. This message is returned using the old baud rate. Then the new baud rate will be applied for subsequent messages.

2B (request product ID): MODBUS reserved function. The return data value is a 26 character string broken down into three MODBUS defined data fields. MODBUS requires more overhead for this function than the REGAL defined functions above.

Function request (client) msg:

START	ADDRESS	FUNCTION	MEI TYPE	
:	XX	2B	0E	
READ CODE	OBJECT ID	LRC	END	
01-04	00-FF	XX	CRLF	

The MEI type field is always 0E for this function. The REGAL monitors return the basic device ID, required by MODBUS, in a single response msg (read code compliance level is 01). The read code and object ID fields are validated, but otherwise unused.

Allowable read codes are 01-04. If a read code other than 01 is sent, the monitor will still respond with a compliance level of 01.

Response (server) msg:

START	ADDRESS	FUNCTION	MEI TYPE	
:	XX	2B	0E	
READ CODE	CONFORMITY	MORE	NEXT OBJ	
01	01	00	00	
# OF OBJ	1st OBJ	BYTE COUNT	DATA	
03	00	05	REGAL	
NEXT OBJ	BYTE COUNT	DATA		
01	10	XXXXXXXXXXXXXXXXXX		
NEXT OBJ	BYTE COUNT	DATA	LRC	END
02	05	VX.XX	XX	CRLF

All the field values above not denoted by X are literal. The three data fields are:

00 Vendor Name: REGAL

01 Product Code: 16 character internal model number

02 Major/Minor Revision: software revision number

EXAMPLE: :7F2B0E0100D9(CRLF) sent to a single sensor SO2 detector at address 7F would return :7F2B0E01010000030005REGAL01103003XFXXX V1.13AE(CRLF). The model number string is always 16 characters even if trailing spaces exist, in this case 7 spaces (ascii 32). The LRC is AE hex, 174 decimal.

NOTE: The model number format is still subject to change.

11.0 SENSOR CROSS-SENSITIVITY DATA

11.1 CHLORINE

The sensors used in all REGAL Series 3000 Chlorine Gas Detectors may exhibit a response to certain gases in a sample stream other than chlorine. The table below shows the typical response of a REGAL chlorine sensor to a number of common cross-interfering gases. The data is given as a percentage of the primary sensitivity (i.e., Chlorine = 100%).

TYPICAL RESPONSE TO CROSS-INTERFERING GASES

CO	H ₂ S	SO ₂	NO	NO ₂	CL ₂	H ₂	HCN	HCl	C ₂ H ₄
0	~-20	0	0	~105	100	0	0	0	0

11.2 SULFUR DIOXIDE

The sensors used in all REGAL Series 3000 Sulfur Dioxide Gas Detectors may exhibit a response to certain gases in a sample stream other than sulfur dioxide. The table below shows the typical response of a REGAL sulfur dioxide sensor and the expected response when exposed to a given test gas concentration (RELEVANT TO SAFETY, e.g., TLV LEVELS).

GAS	CONCENTRATION	RESPONSE
Carbon Monoxide	300 PPM	<5 PPM
Hydrogen Sulfide	15 PPM	0 PPM
Nitric Oxide	35 PPM	0 PPM
Nitrogen Dioxide	5 PPM	~-5 PPM
Chlorine	1 PPM	<-0.5 PPM
Hydrogen	100 PPM	0 PPM
Hydrogen Cyanide	10 PPM	<5 PPM
Hydrogen Chloride	5 PPM	0 PPM
Ethylene	100 PPM	0 PPM

DRAWING NO. 1
#4100 Display/CPU Circuit Board
Chlorine and Sulfur Dioxide

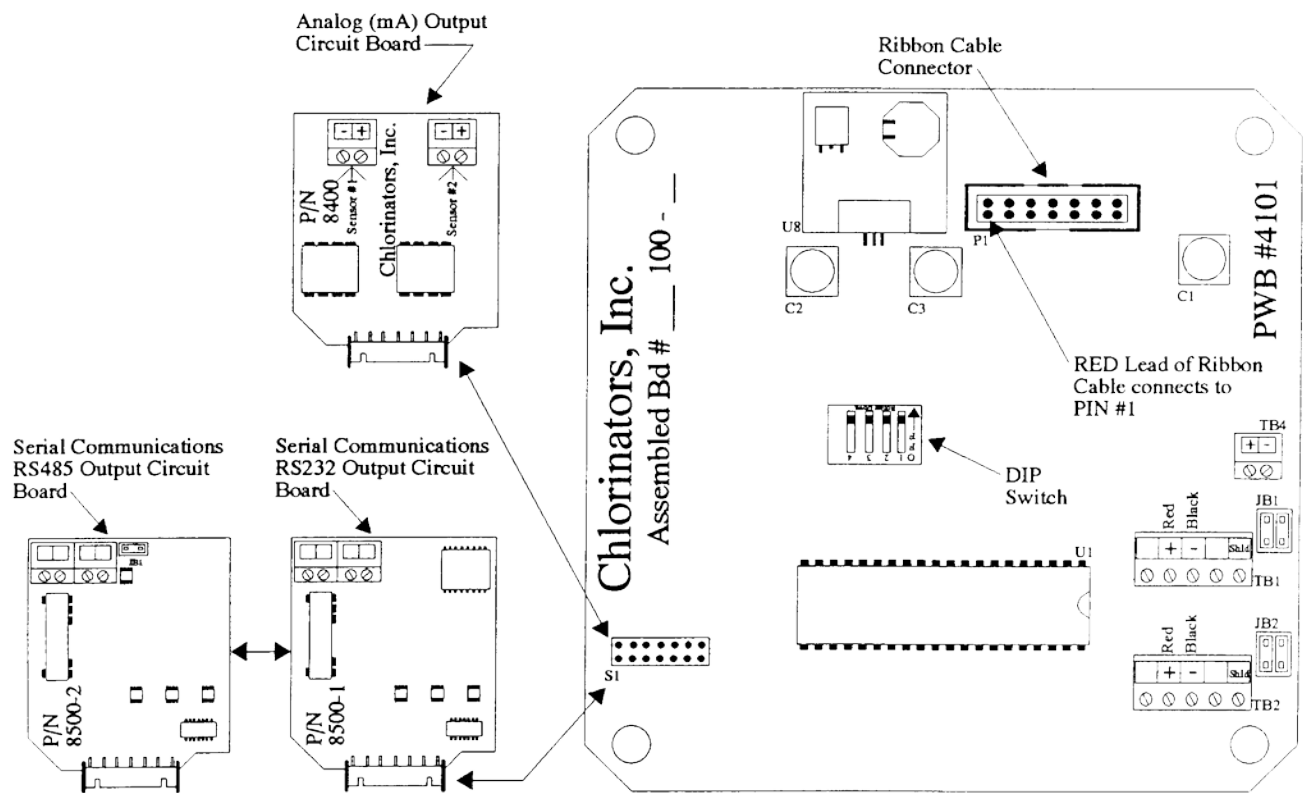

1. S1 This is the connector the #8400 Analog Output (mA) Board or the #8500 Serial Output (Digital) Board plugs into.
2. TB1 This is the connector the Gas Sensor connects to if the unit only has one sensor. BE SURE TO OBSERVE CORRECT POLARITY.
3. TB2 If the unit is a dual sensor Gas Detector, the second Gas Sensor connects here. BE SURE TO OBSERVE CORRECT POLARITY.
4. TB4 This is the connector for the OPTIONAL Battery Back-Up. BE SURE TO OBSERVE CORRECT POLARITY.
5. JB1 This Jumper is set for Gas Sensor Input(s). DO NOT CHANGE.
6. JB2 Same as #5.
7. P1 This is the #1 Pin of the Ribbon Cable Connector. MAKE SURE THE "RED" LEAD OF THE RIBBON CABLE CONNECTS TO PIN #1.
8. P/N 8400 This is the Analog Output Circuit Board (4-20 Milliamps) that plugs into the "S1" connector of the Display/CPU board. BE SURE TO OBSERVE CORRECT POLARITY.
9. P/N 8500 This is the OPTIONAL Serial Communications Output Circuit Board that plugs into the "S1" connector of the Display/CPU board.

NOTES:

- A. Only one board (8400 or 8500) can be used at a time.
- B. DIP Switch Settings are:
 1. Switch Position #1
When in the "OFF" position, the Horn and Relay are on continuously when activated until SILENCED or RESET.
When in the "ON" position, the Horn and Relay "pulse" when activated until SILENCED or RESET.
 2. Switch Position #2
When in the "OFF" position, AUTOCAL is DISABLED.
When in the "ON" position, AUTOCAL is ENABLED.
 3. Switch Position #3
When in the "OFF" position, relay operation is NORMAL.
When in the "ON" position, relay operation is FAILSAFE.
 4. Switch Position #4
When in the "OFF" position, Serial Communications Protocol settings are disabled.
When in the "ON" position, Serial Communications Protocol settings are enabled.

DRAWING NO. 2
#8300 Power Supply PCB Assembly
Chlorine and Sulfur Dioxide

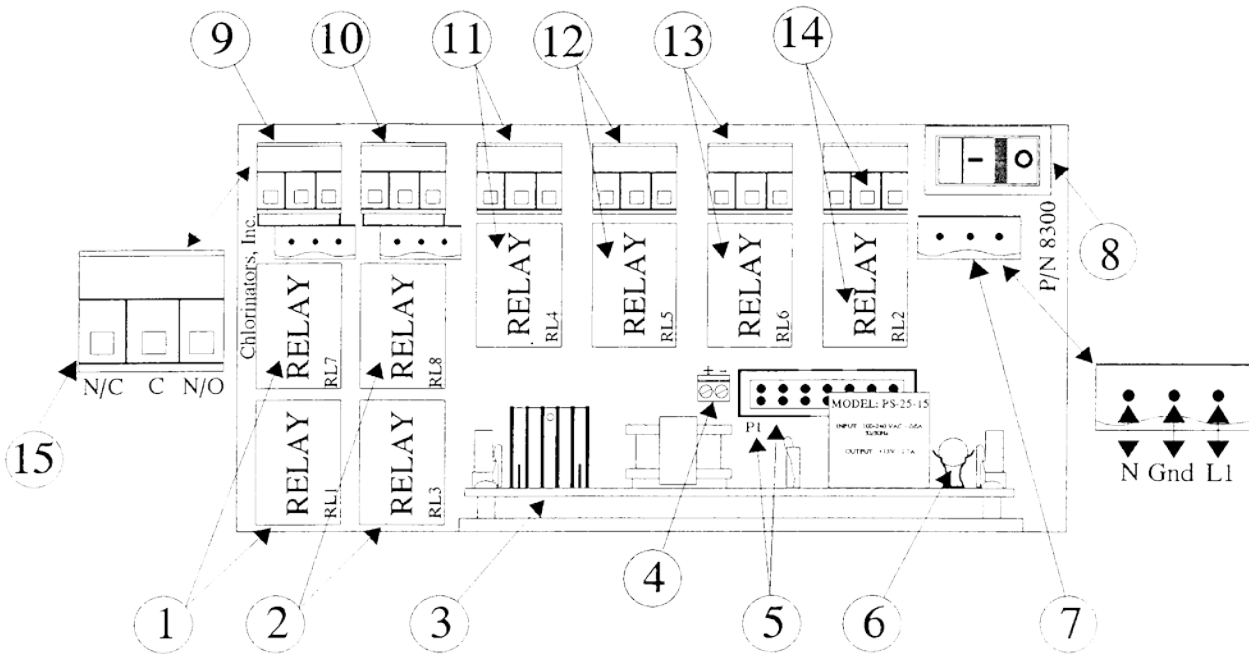

INDEX

1. Double Pole, Double Throw **DANGER** Gas Concentration Alarm Relay (RL1 & RL7) for Sensor #1.
2. Double Pole, Double Throw **DANGER** Gas Concentration Alarm Relay (RL3 & RL8) for Sensor #2.
3. Universal Power Supply (100-240 VAC –50/60 Hz).
4. Connector for internal Alarm Horn. See #14 below.
BE SURE TO OBSERVE CORRECT POLARITY.
5. Ribbon Cable Connector. MAKE SURE THE "RED" LEAD OF THE RIBBON CABLE CONNECTS TO PIN #1 (P1).
6. AC Power Fuse.
7. AC Power Supply Connector.
8. AC power ON/OFF Switch.
9. External Alarm Device Connector for **DANGER** Gas Concentration Alarm Relay #1.
10. External Alarm Device Connector for **DANGER** Gas Concentration Alarm Relay#2.
11. **WARNING** Gas Concentration Alarm Relay (RL4) and Connector for Sensor #1.
12. **WARNING** Gas Concentration Alarm Relay (RL5) and Connector for Sensor #2.
13. LATCH Alarm Relay (RL6) and Connector.
14. Alarm Horn Relay (RL2) and Connector for Horn Circuit.
15. Relay designation as shown on this "blow up" is the same for all relays furnished.

DRAWING NO. 3
Typical Wiring Schematics
Chlorine and Sulfur Dioxide

A. Typical wiring schematic of the 4-20 mA Output Circuit Board.

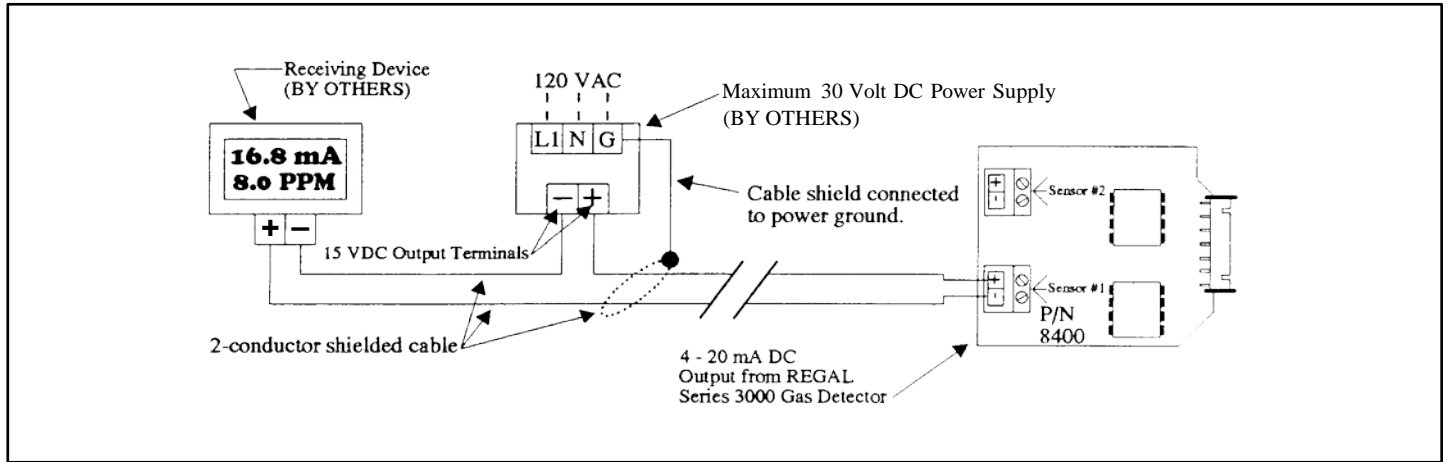

B. Typical wiring schematic of the OPTIONAL RS232 Serial Output Circuit Board.

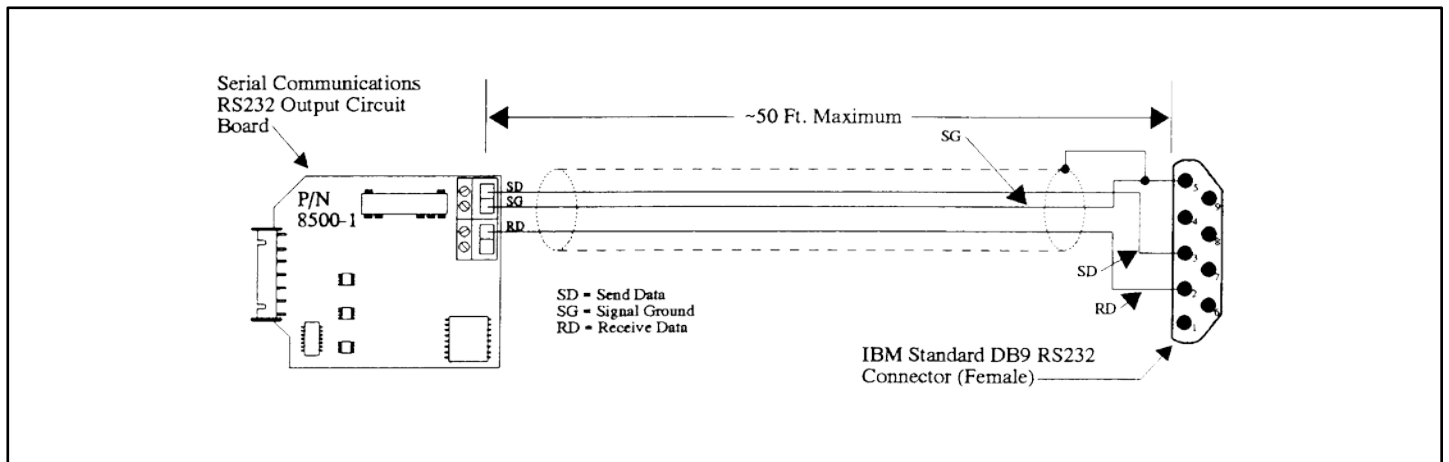

C. Typical wiring schematic of the OPTIONAL RS485 Serial Output Circuit Board.

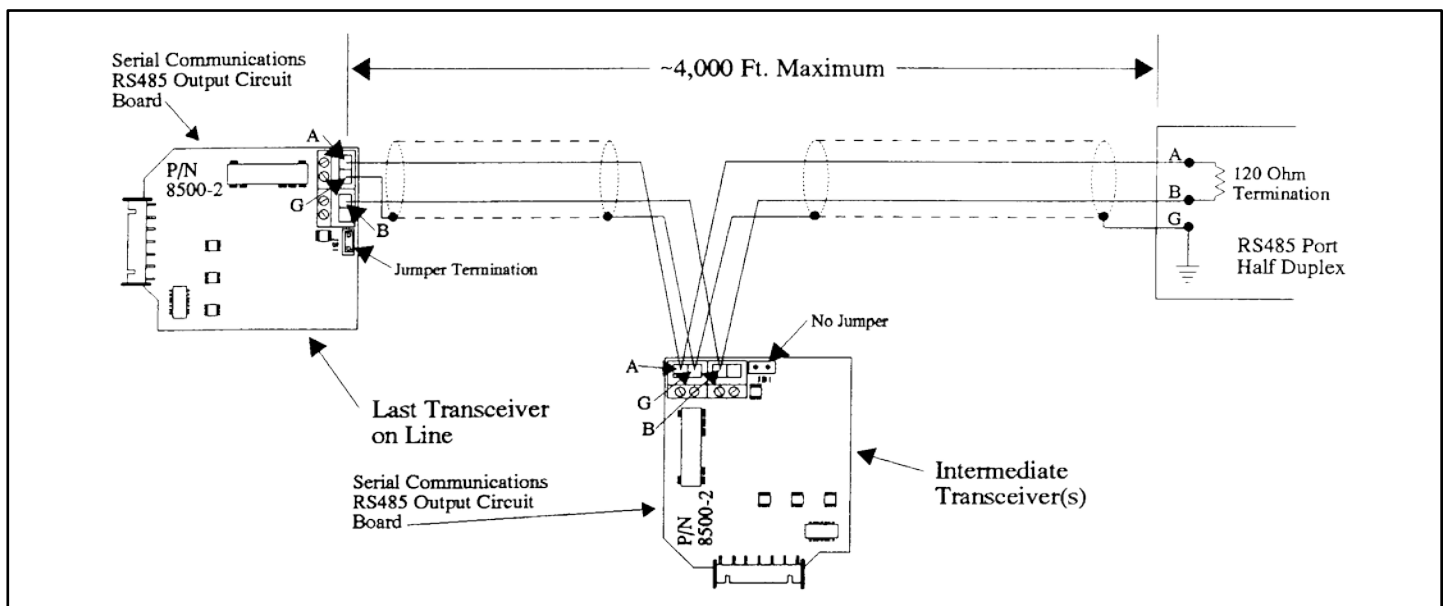

DRAWING NO. 4A
REGAL Series 3000 Gas Detector (Chlorine or Sulfur Dioxide)
Typical Installation - 1 Sensor

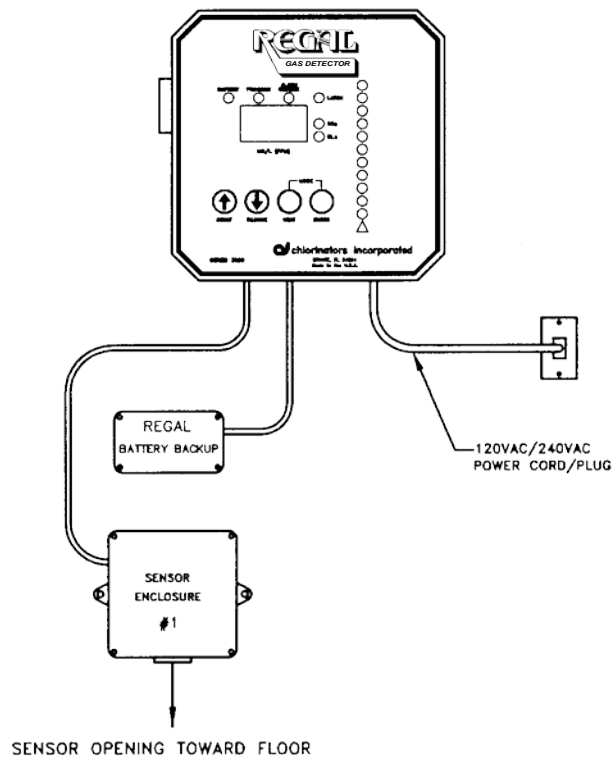

DRAWING NO. 4B
REGAL Series 3000 Gas Detector (Chlorine, Sulfur Dioxide or Chlorine and Sulfur Dioxide)
Typical Installation - 2 Sensors

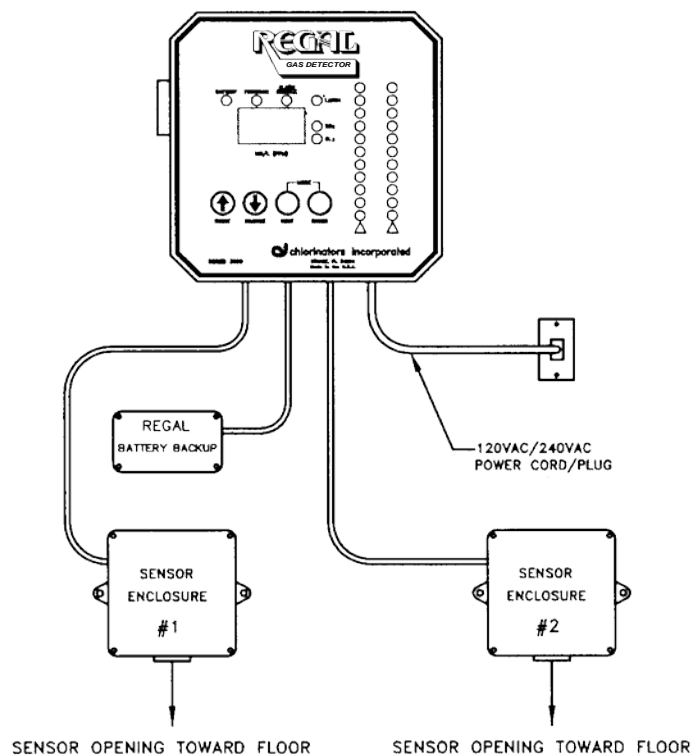

DRAWING NO. 5
REGAL Series 3000 Gas Detector (Chlorine and Sulfur Dioxide)
Faceplates

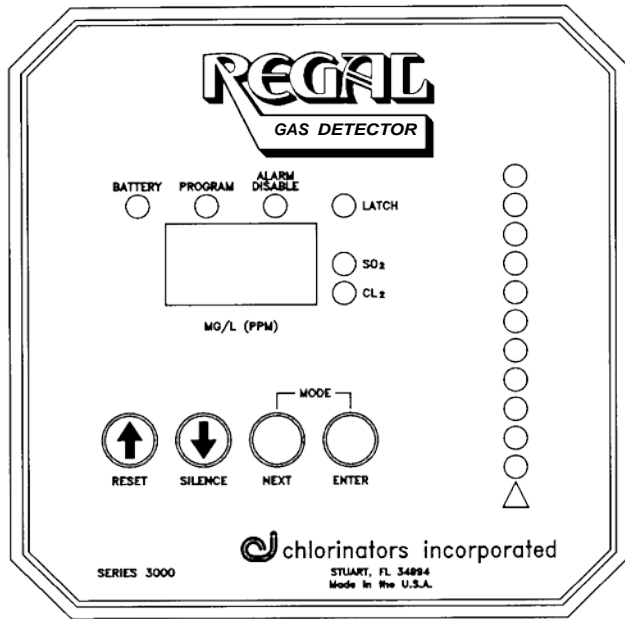

Gas Detector — 1 Sensor

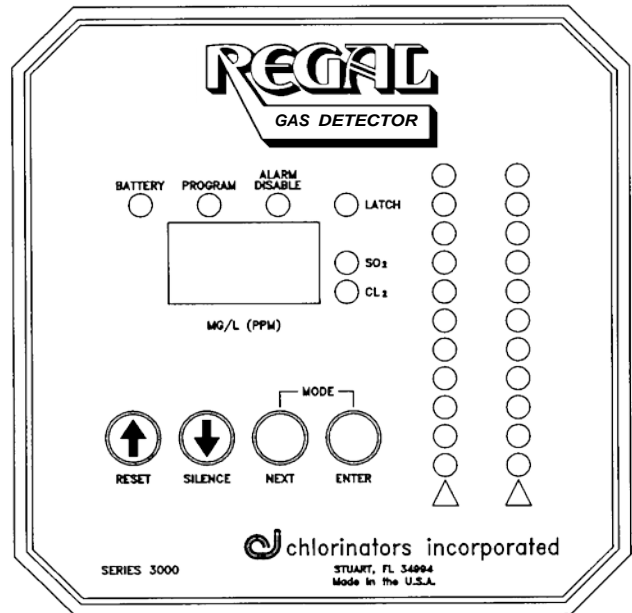

Gas Detector — 2 Sensors

DRAWING NO. 6
Wiring Diagram

Remote alarm light and Chlorine room exhaust fan connections showing the exhaust fan connected to danger relay RL1 and the alarm light connected to warning relay RL4

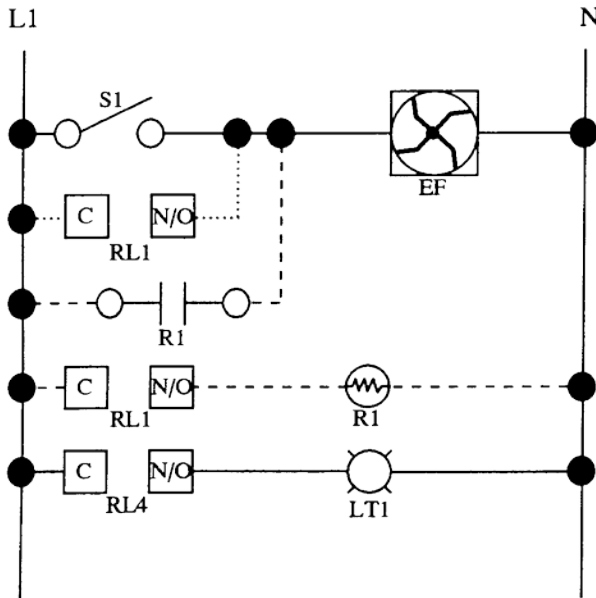

- Wiring required for all connections
- - - - - Wiring required if exhaust fan current draw is less than 10 amps
- - - - - Wiring required if exhaust fan current draw is greater than 10 amps

LEGEND DEFINITIONS

- EF = Exhaust Fan (BY OTHERS)
- RL1 = DANGER Relay Terminal - Series 3000
- RL4 = WARNING Relay Terminal - Series 3000
- LT1 = External Alarm Light/Horn, etc. (BY OTHERS)
- R1 = Exhaust Fan Control Relay (BY OTHERS – Contact rating MUST be sufficient to operate fan)
- S1 = Exhaust Fan On/Off Switch (BY OTHERS)

DRAWING NO. 7
Connecting the REGAL VAC/AL-1 Remote Alarm Horn/Light
Chlorine and Sulfur Dioxide

This drawing shows the strobe light connected to one of the "WARNING" relays and the alarm horn connected to one of the "DANGER" relays.

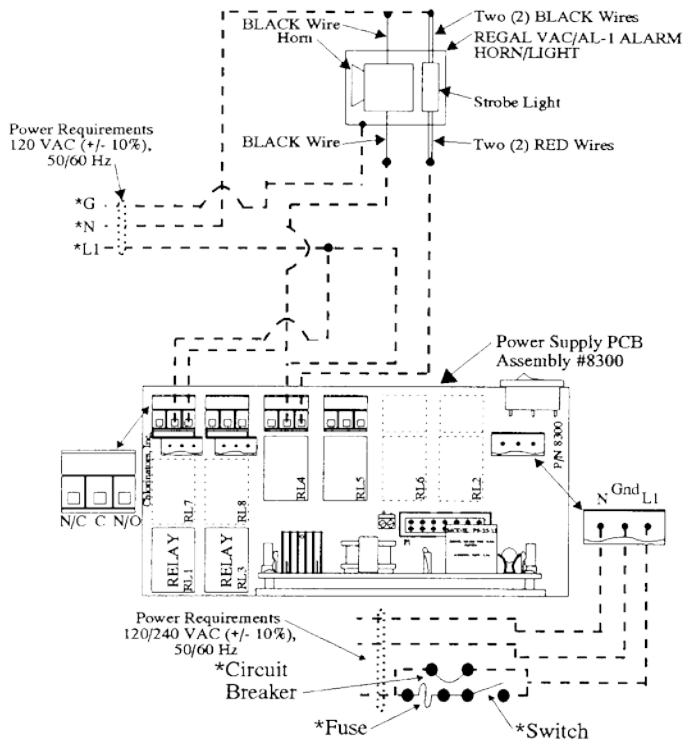

This drawing shows the strobe light and the alarm horn connected to a common relay, in this case, a "DANGER" relay.

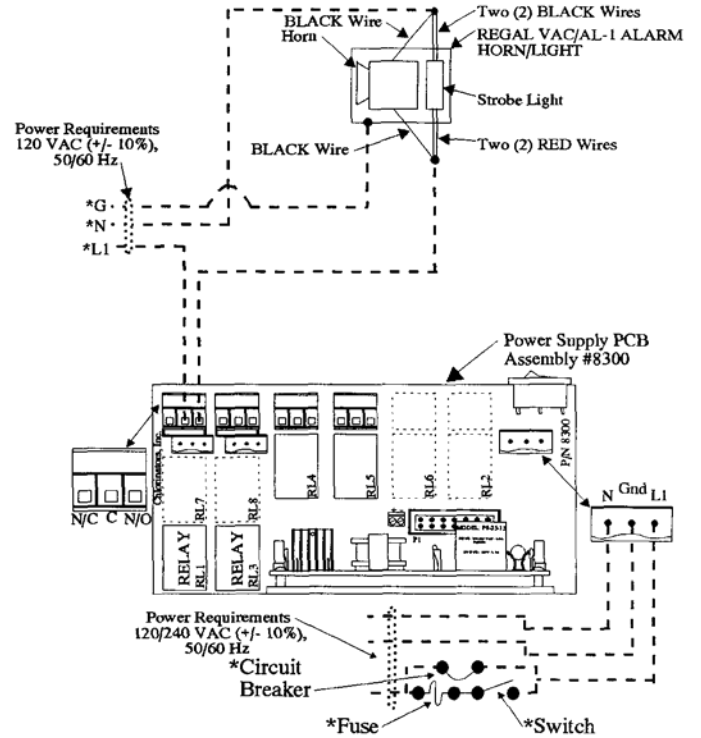

NOTE

All wiring should be done by a licensed electrician as any equipment powered by AC line voltage represents a potential shock hazard that could cause death.

Always disconnect power before removing the cover or performing service on this equipment.

All wiring must conform to national and local codes.

* By Others

DRAWING NO. 8
Sensor Replacement
Chlorine and Sulfur Dioxide

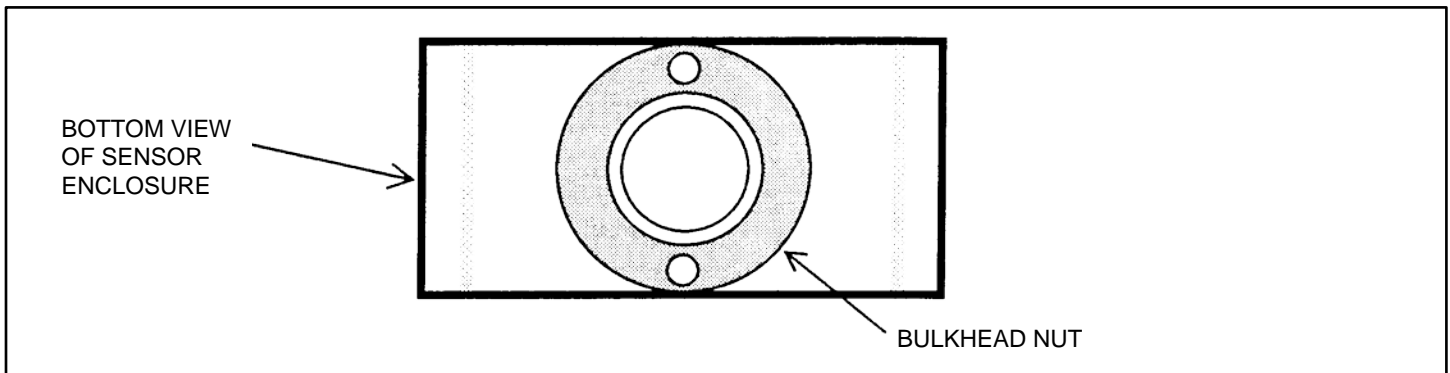
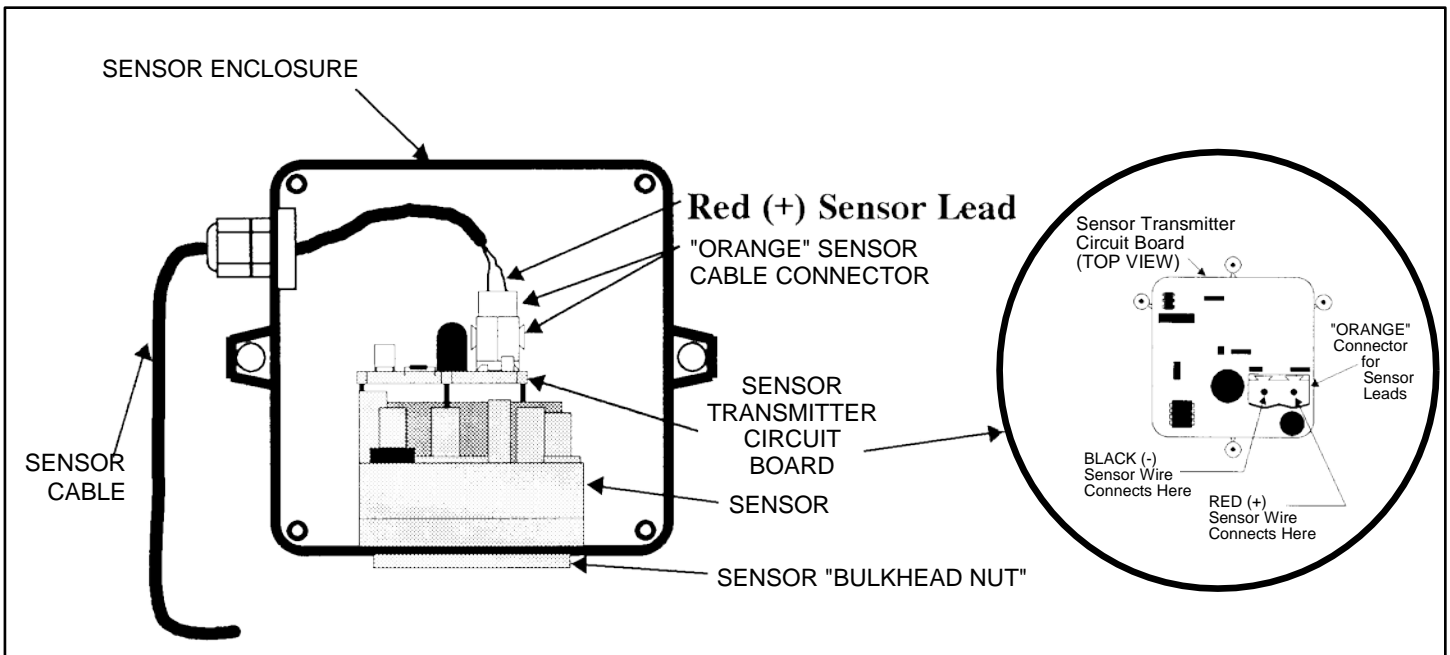

NOTES:

1. The sensor and the sensor circuit board are replaced as an assembly.
2. **DO NOT** overtighten the "bulkhead nut" as damage to the sensor could occur.
3. Be sure to observe correct polarity of the sensor signal wires when connecting to the connector on the sensor transmitter circuit board.

REPLACEMENT PROCEDURE

1. If the sensor enclosure is mounted on a wall, remove the enclosure from the wall to more easily enable removal of the sensor.
2. Remove the cover from the sensor enclosure by removing the four (4) corner screws holding the cover in place and set aside.
3. Carefully unplug the "orange" connector from the Sensor Transmitter Circuit Board. **MAKE SURE THE TRANSMITTER BOARD DOES NOT UNPLUG FROM THE SENSOR BASE.**
4. The sensor is held into the sensor enclosure by means of a "bulkhead nut." Using a pair of needle nose pliers inserted in the two (2) holes of the bulkhead nut, carefully unscrew (counterclockwise) the bulkhead nut and set aside, then lift out the used sensor.
5. Install the new sensor into the sensor enclosure by reversing steps #1 through #4.

DRAWING NO. 9
Engineering Data Sheet
Series 3000 Gas Detector Enclosure Dimensions

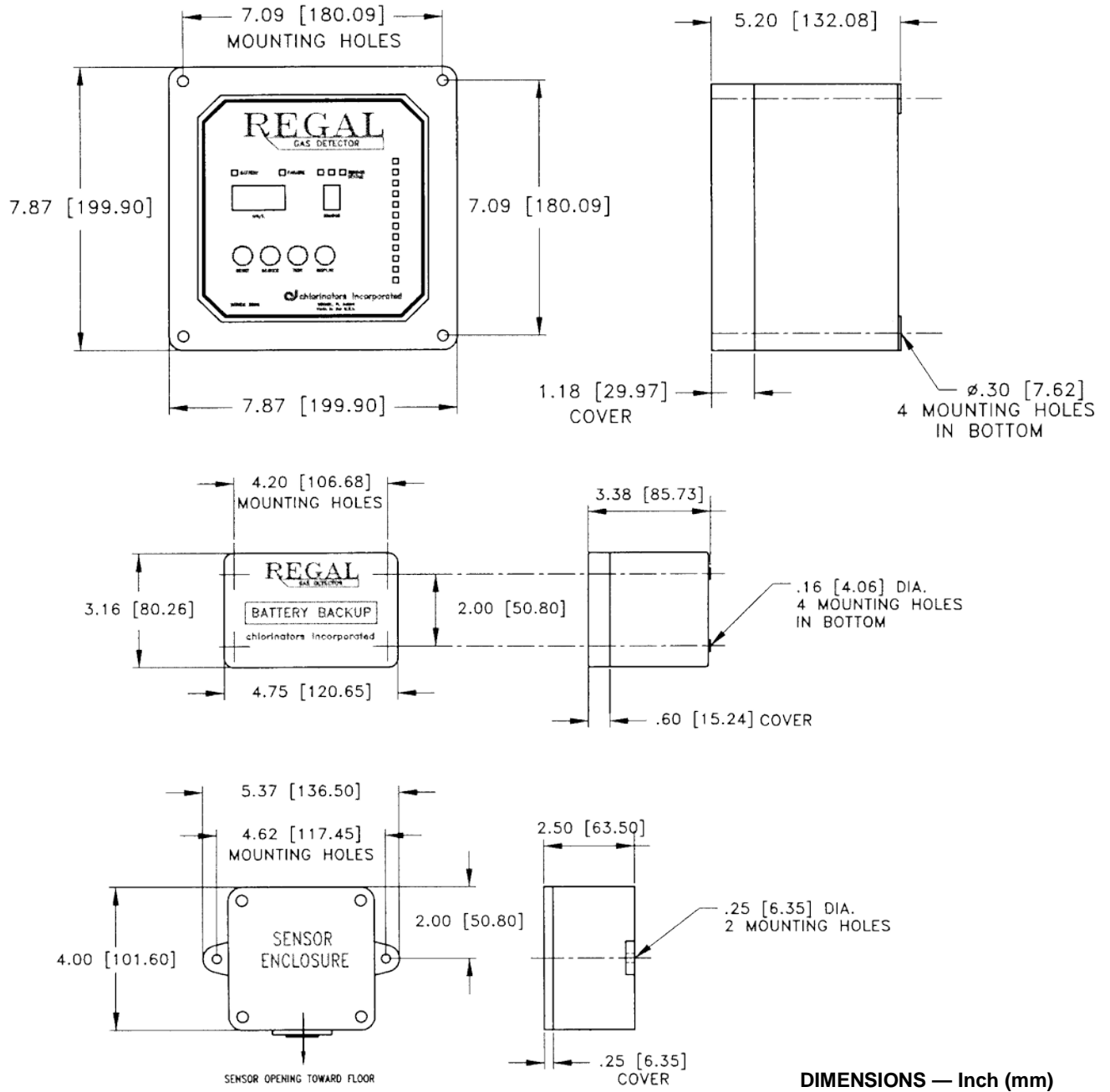

DIMENSIONS — Inch (mm)

 chlorinators incorporated

Copyright ©2005, Chlorinators Incorporated.

App4Water
2 Forest Drive
Catonsville, MD 21228
410.744.9040 *phone*
410.744.6062 *fax*
www.app4water.com

Printed in U.S.A.
Pub. No. 905-6